



# GENUINE PARTS

## INSTALLATION INSTRUCTIONS

<b>DESCRIPTION:</b>	Rear Bumper Step Assist
<b>APPLICATION:</b>	Nissan Titan (2016)
<b>PART NUMBER:</b>	999T7 W4800

### KIT CONTENTS:

Item	Qty.	Part Description
A	1	Linkage Assembly
B	1	Assembly Mount
C	1	Bumper Bracket
D	1	Step Pad
E	1	Hardware Kit
F	2	Bolt Hex 10mm x 65mm 81-B7245-2A
G	2	Washer 10mm
H	2	Bolt Hex Flange 12mm x 45mm
I	3	Delta PT Screw M5 x 20mm
J	1	M6 Flange Bolt
K	1	M6 Flange Nut
L	1	Installation Instructions Replacement Template

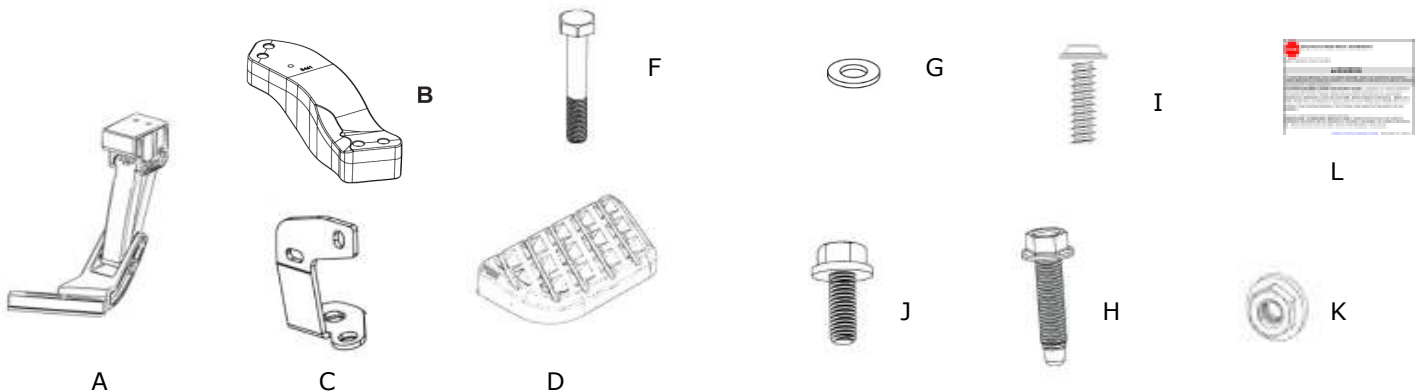

### TOOLS REQUIRED:

- Socket Wrench
- 9" Extension
- 18mm Socket (Short Socket)
- 3/16" Hex Bit Socket
- Torque Wrench

### PRE-INSTALLATION WARNINGS, CAUTIONS, CRITICAL STEPS, and NOTES:

- Dealer Installation Recommended. Instructions may refer to Service Manual.

### WARNING

- Be careful of sharp edges under vehicle.
- Bolts must be tightened to specified torque values.

**INSTALLATION PROCEDURE:** (continue)

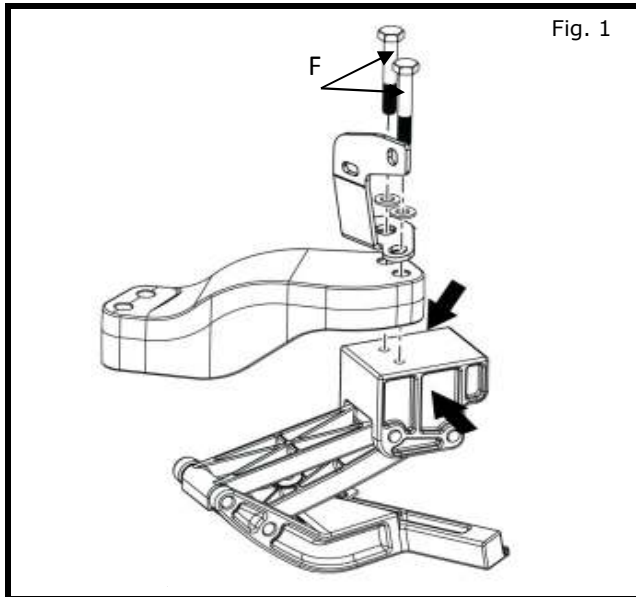

- 1) Raise and secure vehicle on lift.
  - 2) Secure linkage assembly in vice at points indicated by arrows in Fig. 1.
- NOTE:**  
**Protect (cover) part with cloth when place in vice to avoid paint damage.**
- 3) Orient all parts as shown in Figure 1 and torque (2) hex bolts (F) to 33 ft-lbs (44 Nm).

**NOTE:**  
**Keep step pad linkage assembly in closed or stowed position.**

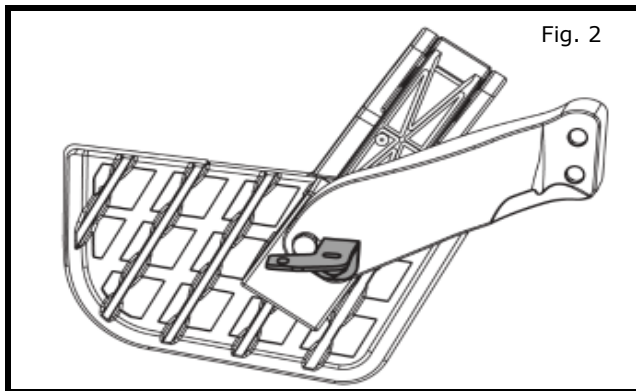

**NOTE:**  
**Ensure bracket is installed in orientation shown in Figure 2.**

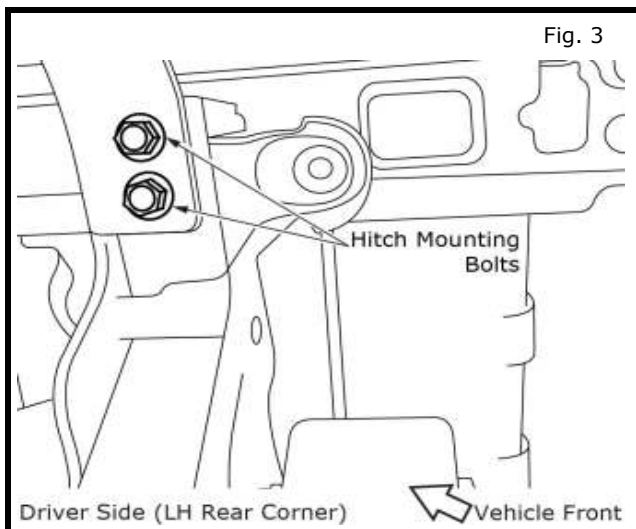

- 4) Remove (2) hitch mounting bolts as shown in Fig. 3.

**INSTALLATION PROCEDURE:** (continued)

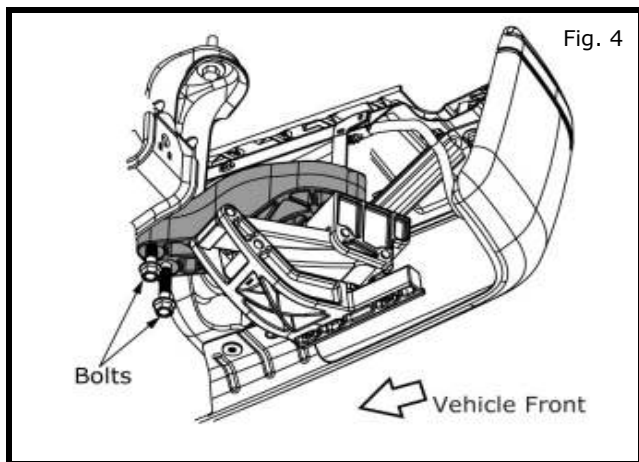

- 5) Install two (2) replacement bolts into assembly mount through hitch member as shown in Fig. 4. Hand tighten bolts.

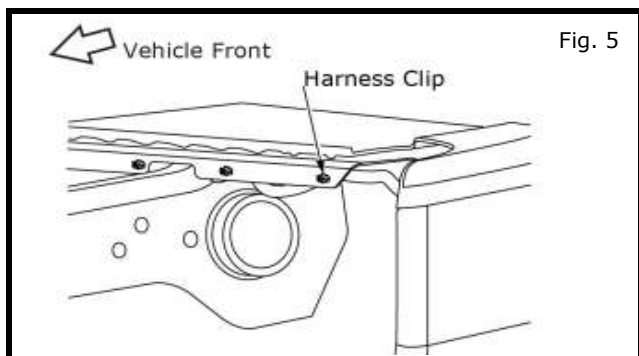

- 6) Locate outermost harness retainer clip as shown in illustration. Unfasten clip from bumper by pinching both sides of clip.

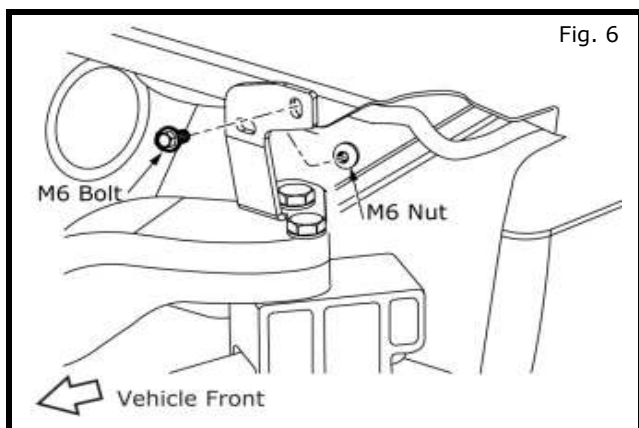

- 7) Using one M6 bolt (J) and one M6 nut (K), attach bumper bracket to bumper using previous clip location. See Fig. 6.
- 8) Tighten (2) hitch mounting bolts (installed in Step 5, Fig 3) to 101 ft-lbs (137 Nm).
- 9) Tighten bumper bracket nut to 53 ft-lbs (72 Nm).

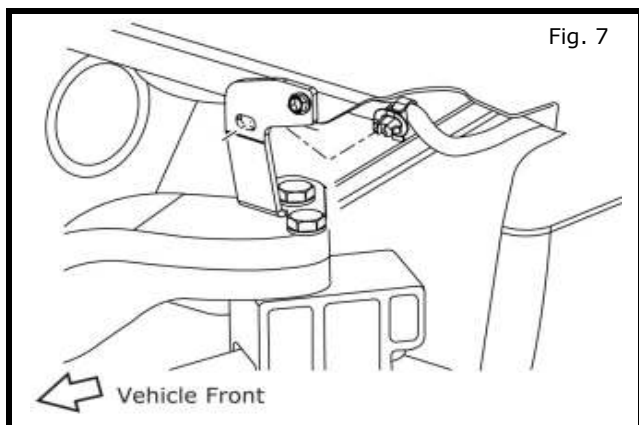

- 10) Attach previously removed harness retainer clip to hole in bumper bracket. See Fig. 7.

**INSTALLATION PROCEDURE:** (continued)

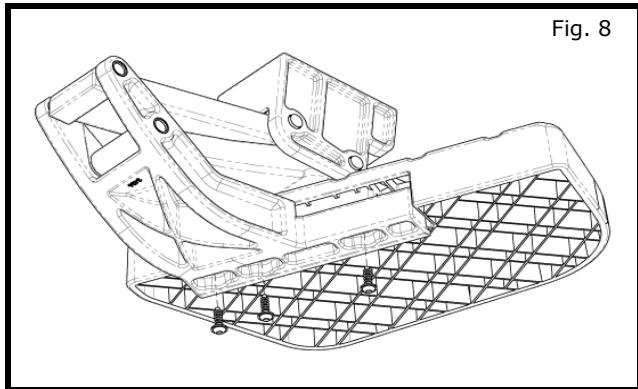

- 11) Mount step pad to linkage assembly as shown in Fig. 4.
  - a) Push linkage assembly into lowered position.
  - b) Insert PT screws into step pad.
  - c) Locate step pad into lower mount of linkage assembly.
- 12) Install pt screw into step pad and tighten to 6 ft-lbs (8 Nm) as shown in Fig. 8.
- 13) Lower vehicle from lift.